

# SYLVANIA



## VISION SERIES

### DESCRIPTION

Vision Series offer a medium size floodlight with the performance of a much larger unit. Compact, rugged and modern looking, this floodlight is the perfect choice for security lighting and floodlight. Suitable for illumination of buildings, auto dealerships or other areas requiring high performance luminaries. Available from 250w to 400w HPS and MH

### SPECIFICATION

- ⊖ High pressure die cast aluminium housing painted dark bronze .
- ⊖ Front hinged door sealed and gasketed.
- ⊖ Anodized aluminum reflector with wide beam spread.
- ⊖ Heat and shock resistant clear tempered glass.
- ⊖ Ballast housing is attached but separate from optical assembly.
- ⊖ 4KV pulse rated E40 base lamp holder
- ⊖ Trunion mount is standard.
- ⊖ Ambient temperature up to 35°C
- ⊖ Classification IP 65
- ⊖ Insulation Class 1
- ⊖ Complies with EN 60598
- ⊖ TIS 1955-2542

### APPLICATION

Building sites, Architectural features, Facades, Security applications.

VISION SERIES



SYLVANIA (THAILAND) LTD. Tel: 0-2656-9039 (Auto 7 Lines), 0-2254-8885-6 Fax: (66) 0-2254-3369, 0-2254-7786



Certified : Photometric Testing Laboratory  
Quality System AS/NZS ISO9001

## DIMENSION

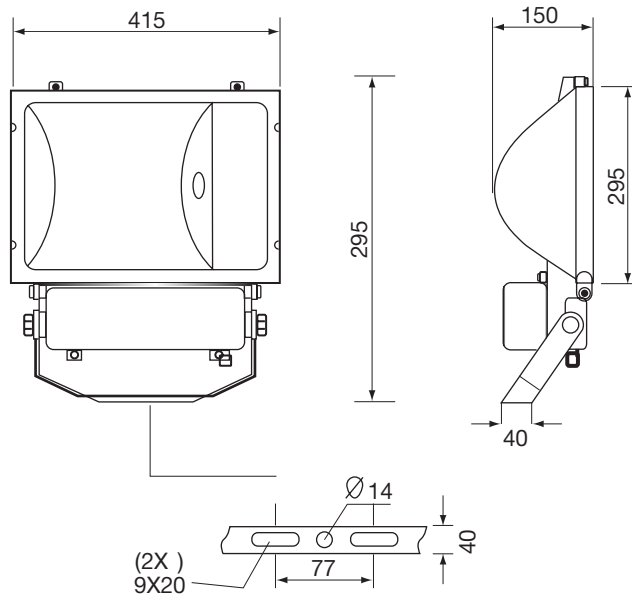

## ORDERING DATA

-Hx87° -V  
Lamp instrument 710 lm  
( cd/1000 lm )

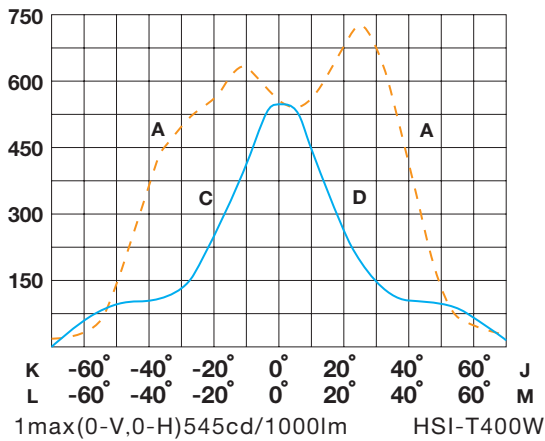
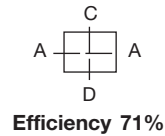

## ORDERING DATA

CAT.NO	LAMP	TYPE	MASS
VISION 250 HPS	SHP-T 250W E40	HIGH PRESSURE SODIUM	10.3
VISION 400 HPS	SHP-T 400W E40	HIGH PRESSURE SODIUM	12.3
VISION 250 MH	HSI-T 250W E40	METAL HALIDE	10.3
VISION 400 MH	HSI-T 400W E40	METAL HALIDE	12.3