

PC T5 PRO Ip, PC TCL PRO Ip, 14 – 80 W

PC PRO T5



Product description

- _ Highest CELMA Energy Efficiency Index A2 BAT
- _ Nominal life-time up to 100,000 h (at ta 50 °C with a failure rate ≤ 0.1 % per 1,000 h)
- _ Large temperature range (for values see table)
- _ Intelligent Voltage Guard (overvoltage indication and undervoltage shutdown)
- _ Precise lamp operation using adjustment of lamp parameters
- _ Advanced SMART-Heating for min. 50,000 starts without replacement of lamps
- _ Constant luminous flux irrespective of fluctuations in mains voltage
- _ Designed for THD < 10 %
- _ For luminaires of protection class I and protection class II
- _ Automatic start after replacement of defective lamps
- _ Safety shutdown of defective lamps and at end of lamp life (EOL 2)
- _ Insulation Displacement Connection (IDC) terminal for rapid automatic or manual wiring
- _ For emergency lighting systems as per EN 50172

Website

<http://www.tridonic.com/22185156>



PC T5 PRO Ip, PC TCL PRO Ip, 14 – 80 W

PC PRO T5

The complete data sheet for this product is available in the Downloads section.

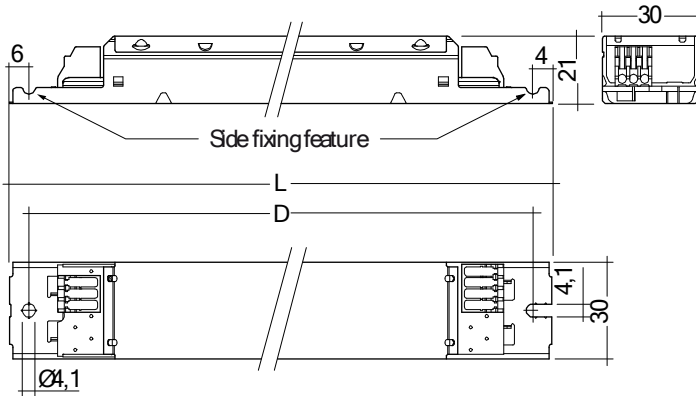

Ordering data

Type	Article number	Packaging, carton	Packaging, low volume	Weight per pc.
For luminaires with 2 lamps				
PC 2x54 T5 PRO Ip	22185156	10 pc(s).	760 pc(s).	0.241 kg

Technical data

Mains voltage range	220 – 240 V
AC voltage range	198 – 264 V
DC voltage range	176 – 280 V (lamp start \geq 198 V DC)
Mains frequency	0 / 50 / 60 Hz
Overvoltage protection	320 V AC, 1 h
Defined warm start	\leq 1.5 s
Operating frequency	\geq 39.5 kHz
Type of protection	IP20

Approval marks



Standards

EN 55015, EN 61347-2-4, EN 61347-2-3, EN 60929, EN 61000-3-2, EN 61547, Acc. to EN 50172, IEC 68-2-64 Fh, IEC 68-2-29 Eb, IEC 68-2-30

Specific technical data

Lamp wattage	Lamp type	Type	Article number	Dimensions L x W x H	Hole spacing D	Lamp power	Circuit power	EEI	Current at 50 Hz		λ at 50 Hz		tc point max.	Ambient temperature ta	tc/ta for \geq 50, 000 h
									220 V	240 V	220 V	240 V			
For luminaires with 2 lamps															
2 x 54 W	T16 (T5)	PC 2x54 T5 PRO Ip	22185156	360 x 30 x 21 mm	350 mm	108.2 W	113.5 W	A2 BAT	0.518 A	0.465 A	0.99	0.97	80 °C	-25 ... +55 °C	75/50 °C